

The Pros and Cons of Using Larger Femoral Heads in Total Hip Arthroplasty

Pranav Rathi, MBBS, MS, Gavin C. Pereira, MBBS, FRCS (Eng), FRCS (T&O), Mauro Giordani, MD, and Paul E. Di Cesare, MD

Abstract

With the introduction of improved bearing surfaces for total hip arthroplasty (THA) has come a reintroduction of larger femoral heads with the promise of reducing the rate of hip instability and increasing hip range of motion (ROM). The size of femoral heads used for THA ranges from 22 to 40 mm, and even larger heads are used for hip resurfacing. With accurately positioned components, larger heads reduce the hip instability rate and theoretically increase hip ROM. However, for any given bearing surface, the volumetric wear rate is higher for larger heads than for smaller heads, which potentially jeopardizes the long-term survival of these reconstructions. In this article, we review the evidence for use of larger femoral heads with respect to stability, ROM, impingement, wear rate, bearing surfaces, and future directions.

Recent advances in total hip arthroplasty (THA) bearing materials, such as cross-linked polyethylene, ceramics, and metal, have reduced the rate of bearing wear. The prospect of decreased wear (attributed to improved bearing materials) and the perception of a lowered rate of hip dislocation have prompted surgeons to use larger femoral heads for THA. The validity of this approach has not been proved. Femoral heads ranging from 22 to 40 mm are available for THA, and even larger heads are used for hip resurfacing. Both the type of material and size selected for femoral heads may affect dislocation rate, linear wear, and range of motion (ROM).

In this article, we review the evidence for use of larger femoral heads with respect to stability, ROM, impingement, wear rate, bearing surfaces, and future directions.

Dislocation rates are 0.5% to 10% for primary THA¹ and 10% to 25% for revision THA.² Up to one-third of hip dislocations become recurrent and require revision surgery.³ Every closed reduction episode increases hospital costs—by 19% for an uncomplicated THA—and by 148% for a revision THA.⁴

Twenty-five percent of all revisions are performed for instability or dislocation.³

Total Hip Arthroplasty Stability and Jump Distance

Jump distance (JD) is the femoral head center translation distance required for a head to dislocate from a socket (Figure 1). Prosthetic hips with less JD are more likely to dislocate than hips with more JD. Sariali and colleagues⁵ found that JD varies according to cup abduction angle (angle of rotation around anterior-posterior axis of pelvis), cup anteversion angle (angle of rotation around cranial-caudal axis of pelvis), femoral head diameter, and cup center offset.

Cup center offset is the shortest distance from the center of the head to the opening plane of the cup (Figures 2A-C). The offset is positive when the head center lies outside the opening

Figure 1. Jump distance (JD): distance of translation of femoral head center required for head to dislocate from cup. Prosthetic hips with less JD are likelier to dislocate more easily than those with more JD.

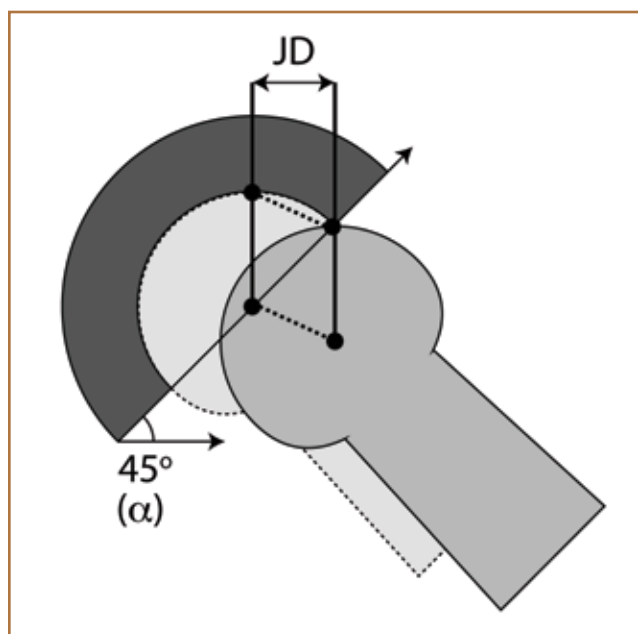

Authors' Disclosure Statement: The authors report no actual or potential conflict of interest in relation to this article.

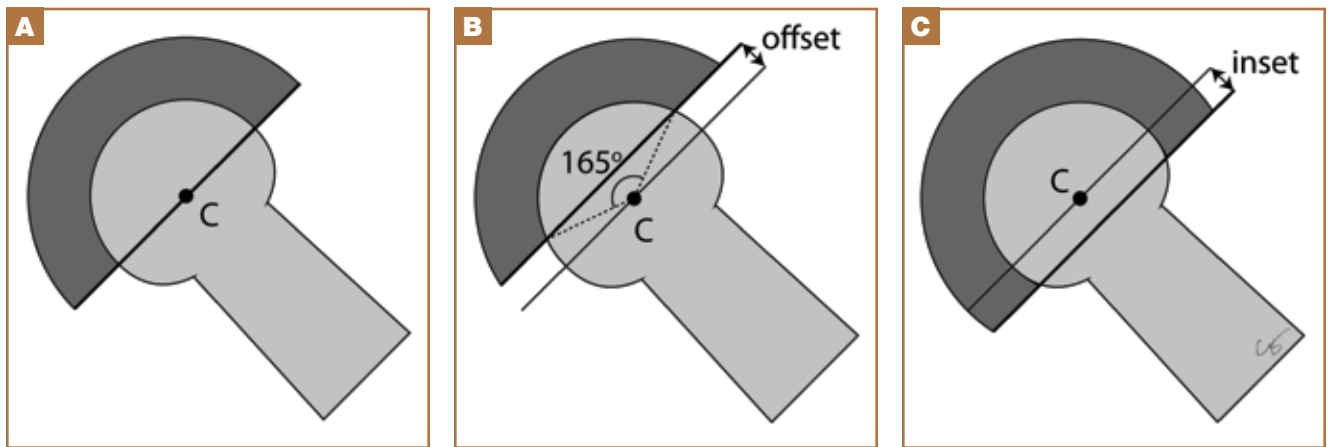

Figure 2. Cup center offset: neutral (A), positive (B), and negative or inset (C).

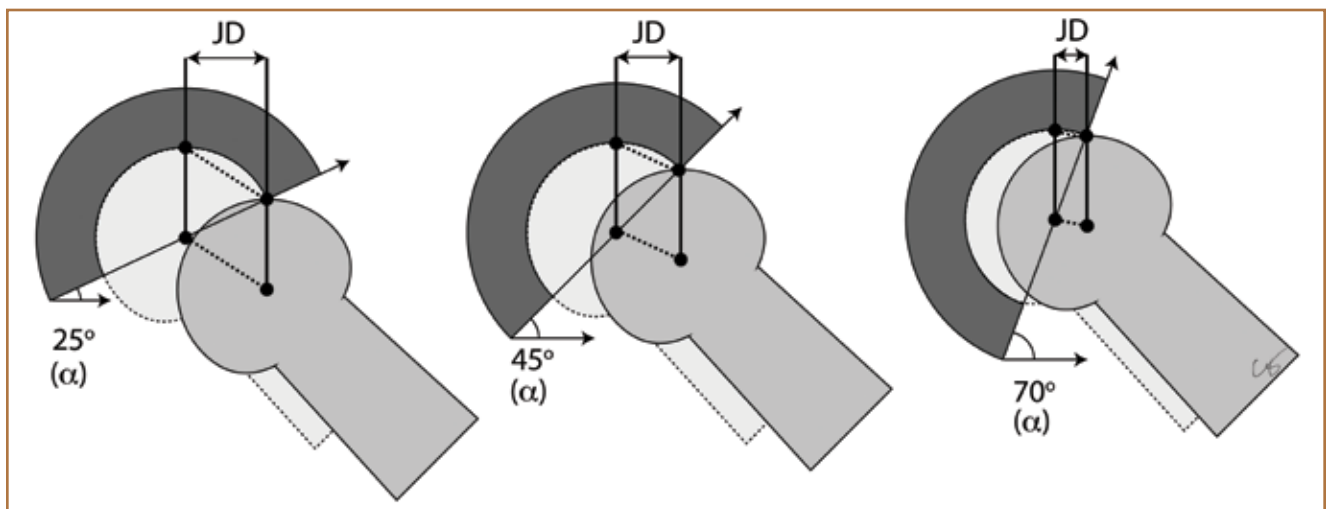

Figure 3. Jump distance (JD) decreases as cup abduction angle increases from 25° to 70°.

plane of the cup, which is the case when the cup is not a full hemisphere or when the acetabular liner is offset to increase the amount of material medially in the polyethylene liner. The offset is *negative* (and is called an *inset*) when the head center lies inside the opening plane of the cup.

The surgeon controls the variables of cup abduction angle, cup anteversion angle, and femoral head diameter, and JD is calculated as follows:

$$JD = 2R \times \left[\frac{\pi}{2} \theta \arcsin\left(\frac{\text{offset}}{R}\right) \right]$$

where R = femoral head radius, θ = planar cup inclination angle, and offset = cup center offset. The planar cup inclination angle is given by:

$$\Theta = \arctan [\tan \alpha \times \cos \beta]$$

where α = abduction angle of cup, and β = anteversion angle of cup.

It is only partly true that JD increases with femoral head diameter. The equation highlights that JD depends not only on femoral head size, but also on orientation of the implanted cup and on cup offset. The position of the implanted cup in turn has 2 variables that affect JD: abduction angle and anteversion angle.

For a constant anteversion angle and a constant femoral head size, JD is inversely related to the abduction angle (Figure 3). For example, for a 32-mm head, JD decreases about 0.25 mm for each 1° increase in abduction angle.

With respect to constant anteversion angle and constant abduction angle, JD is directly related to femoral head size. However, this advantage of increased JD is reduced if the cup is implanted with an increased abduction angle, ie, vertical cup placement.

For an acetabular component at an abduction angle of 30°, JD increases 0.5 mm for each 1-mm increase in head diameter; at an abduction angle of 45°, JD increases 0.4 mm; and, at an abduction angle of 60°, JD increases 0.25 mm. The JD increase

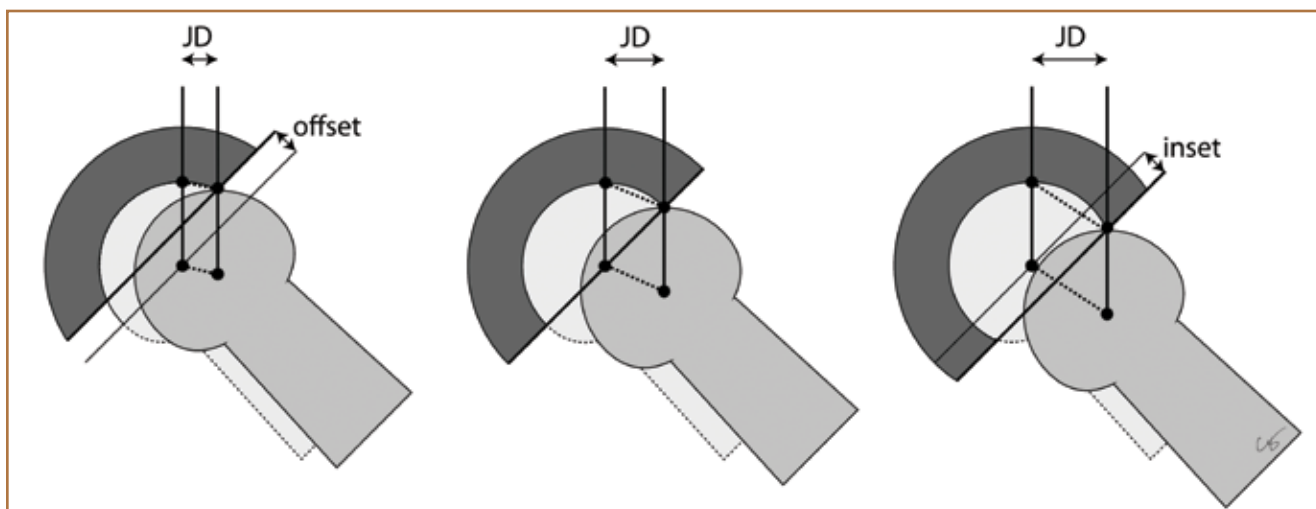

Figure 4. Jump distance decreases as cup center offset increases.

that occurs with larger head diameter depends on the abduction angle/inclination of the cup, and much of that advantage can be lost when the cup is inserted at a higher than desired abduction angle. For example, in a cup inserted at 45° , JD increases from 14.1 mm for a 36-mm head to 15.8 mm for a 48-mm head—a difference of 1.7 mm (12%), which drops to 0.13 mm (1.4%) for a cup abduction angle of 60° .

JD also varies directly with the anteversion of the acetabular component, but this variation has less effect per degree of position change than the abduction angle.⁵ This is because the anteversion angle is a low-value angle (15° - 25°) from the start, and consequently, the trigonometric value of this angle is almost negligible.

The other variable that affects JD is cup center offset. This relationship is inverse, ie, as offset increases, JD decreases. Increasing the offset causes the center of rotation to lay outside the opening plane of the cup, thereby making the cup shallower and increasing susceptibility to dislocation (Figure 4). Decreasing the offset, or having an inset (as in a constrained liner), can increase the risk for impingement. However, Bunn and colleagues⁶ studied ROM in a computer-generated pelvis with a Secur-Fit Max Femoral Hip Stem (Stryker Orthopaedics, Mahwah, New Jersey) and a Trident Acetabular Cup System (hemispherical with 0 cup center offset; Stryker Orthopaedics, Mahwah, New Jersey) and concluded that bony impingement—not implant impingement—reduced ROM.

As femoral head size increases, the polyethylene liner thins to accommodate it, but only to a point (the liner has a certain minimum thickness). Therefore, femoral heads larger than 38 mm require larger acetabular components so that a liner of at least minimum permissible thickness can be used. In theory, the surgeon can decide to ream for a larger cup to accommodate the larger head, creating more acetabular bone loss. To reduce this bone loss, manufacturers pair large femoral heads with acetabular components that are truncated hemispheres of 165° , instead of 180° . These pairings result in a positive

femoral head offset at the start. For a 1-mm increase in head offset, JD is decreased by 0.92 mm. Generally, in large-diameter head–cup couples (head size, >38 mm), the head offset is increased by about 3 mm. In these cases, JD is 2.76 mm less than the JD for a corresponding hemispherical cup design. When comparing JD for a 32- to 40-mm head diameter, one must consider the acetabular couple and the respective femoral head offset because each may have a similar JD. This is why use of very large heads results in a smaller increase in JD than expected, and may be why similar dislocation rates are found in comparisons of 32-mm heads and larger heads.⁵

The biomechanical basis for the increased stability of larger femoral heads in THA has received support from clinical data. According to an analysis of 42,987 primary THAs from 1987 to 2000 (The Norwegian Arthroplasty Registry), the rate of revision surgery for instability was lower for patients with larger femoral heads (30-32 mm) than for patients with smaller femoral heads (≤ 28 mm).⁷ In a separate analysis of a polished, tapered, cemented stem (Exeter; Howmedica Osteonics, Caen, France) and an all-polyethylene, cemented cup (Exeter; Howmedica Osteonics, Caen, France) used in THAs with 26-, 28-, and 30-mm heads (same registry), the reoperation rate was higher for patients with 26-mm heads (because of dislocation) than for patients with 30-mm heads.⁷ The higher reoperation risk after dislocation persisted even after adjusting for several potential confounders. It should be noted that this registry did not capture hip dislocations for which there was no reoperative repair.

In 2005, the Mayo Clinic reported on 21,047 THAs performed between 1969 and 1999 to determine the effect of femoral head diameter on risk for dislocation.⁸ Many factors were stratified and adjusted to isolate head diameter as a single variable. Results showed that larger heads were associated with lower risk for hip dislocation. The dislocation risk was highest for 22-mm heads, intermediate for 28-mm heads, and lowest for 32-mm heads. To determine the rate of dislocation 3, 6,

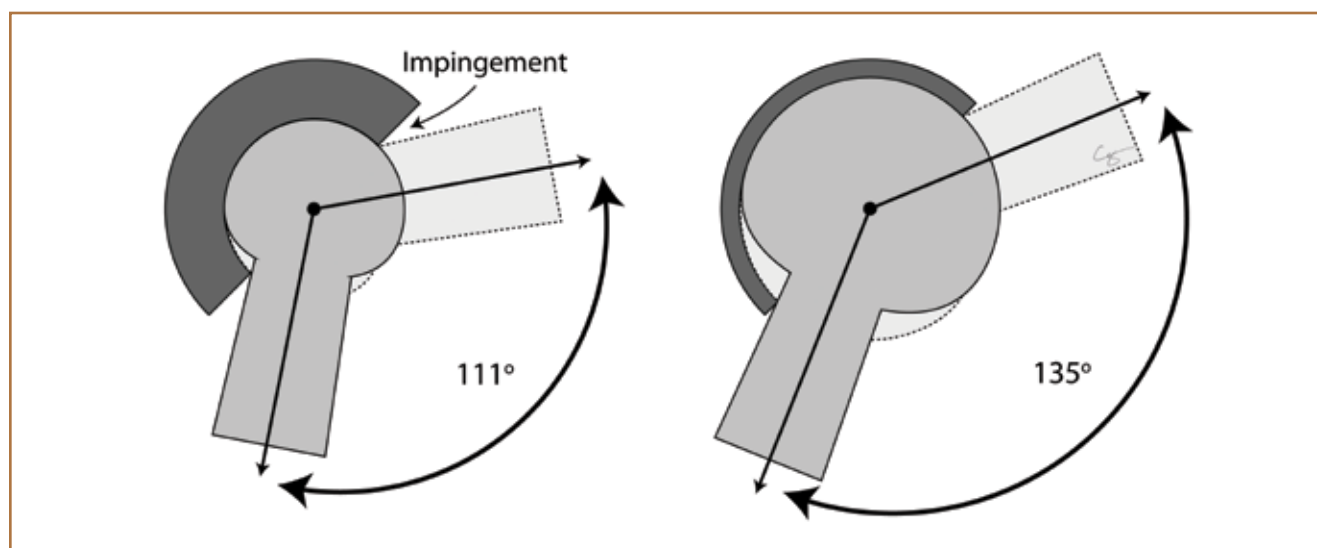

Figure 5. Larger femoral head increases hip range of motion from 111° to 135°. Increased impingement-free range of motion should reduce hip instability rate.

12, and 18 months after THA, investigators analyzed 247,546 procedures performed between 2004 and 2009 (National Joint Registry of England and Wales).⁹ There was a statistically significant increase in use of large-diameter femoral heads (≥ 36 mm), from 5% in 2005 to 26% in 2009, along with a concomitant increase in use of the posterior approach, from 34% in 2004 to 57% in 2009. The compiled data revealed a significant reduction in dislocations associated with larger femoral heads, even when implanted through a posterior approach.

In another recent retrospective review, the 0.05% dislocation rate found for 2020 primary THAs with larger femoral heads (>36 mm) was lower than the rate (0.8%) for 1518 primary THAs with smaller femoral heads (≤ 32 mm); the difference was significant ($P < .001$).¹⁰

In summary, larger diameter femoral heads reduce the dislocation rate in primary THA and revision THA, but this advantage becomes less well-defined for femoral heads larger than 38 mm. There appears to be a sound biomechanical basis for these results, and the clinical outcome data substantiate these findings. Larger femoral heads can be used advantageously in patients at increased risk for hip dislocation; however, the advantage of larger heads can be lost when the acetabular component is not positioned correctly.

Range of Motion

ROM after THA depends on many factors, including patient factors (eg, obesity, preoperative functional status), physiotherapy adherence, surgical factors (eg, approach), component placement, and implant design (eg, femoral head diameter, head-neck ratio, neck length).¹¹⁻¹⁴ Increased ROM, however, may come at the cost of hip stability, with increased risk for impingement along with increased bearing wear. Prosthetic impingement determines the functional endpoint of stable ROM after THA. In THA, impingement can occur between

the prosthetic femoral neck and the cup liner or shell, and bone-to-bone contact can occur between the femur (greater trochanter) and the pelvis.¹⁵⁻¹⁷

In prosthetic hips, a head-neck ratio of less than 2.0 reduces ROM and significantly increases risk for impingement. An increase in head diameter increases ROM primarily by increasing the head-neck ratio (Figure 5). The head-neck ratio depends on head size, femoral neck geometry, and use of a skirt on the femoral head.¹⁸⁻²⁰ Use of a larger head also ensures an acceptable head-neck ratio irrespective of neck geometry and taper modes.

D'Lima and colleagues¹⁴ reported a nonlinear relationship between femoral head size and hip ROM. There was more improvement in hip ROM when femoral head size increased to 26 mm (from 22 mm) than when it increased to 32 mm (from 28 mm), despite the increases being the same (4 mm). The study results showed a plateau in the advantage of using larger femoral heads.

Cup orientation and femoral head size also affect hip ROM. Maximal impingement-free ROM occurred with cup abduction angles between 35° and 45° and cup anteversion angles between 0° and 10°. Higher cup abduction angles result in increased hip flexion, extension, and external rotation,¹⁴ though this is associated with decreased hip stability. Increasing femoral head size can result in increased prosthetic impingement-free ROM. However, if the abduction angle of the cup is increased, the larger head will contribute little to increased hip stability and may result in accelerated wear.²²

Clinical evidence of the effect of head diameter on actual ROM is not as convincing as the evidence for the decreased rate of dislocation with larger diameter femoral heads. Mont and colleagues²³ performed gait analyses to compare hip resurfacing (large-diameter femoral heads), standard THA, osteoarthritic hips (native), and normal hips. Patients with hip

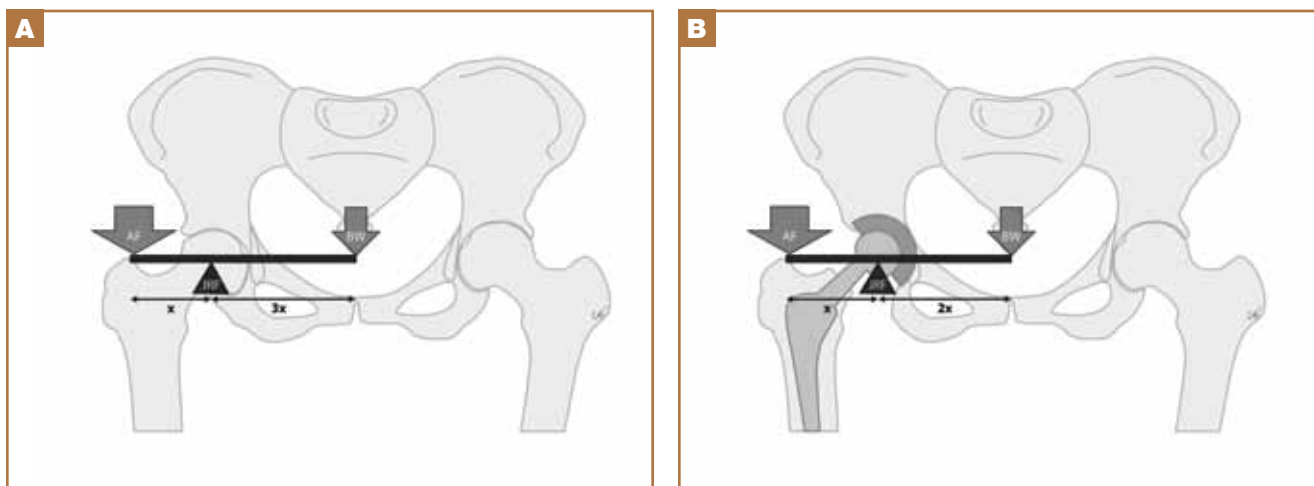

Figure 6. Joint center moved medially compared with native hip (A), minimizing joint forces (B). AF: abductor lever arm, BW: body weight, JRF: joint reduction force.

resurfacing walked faster and with a gait comparable to individuals with normal hips while those with standard THA walked slower. However, the resurfacing and THA groups had similar hip abduction and extensor movements. The authors suggested this was attributable primarily to use of larger diameter femoral heads, which they postulated restore the kinematics of artificial hips more closely to that of normal native hips. These findings were corroborated in a clinical study in which digital photographs and bony landmarks were used to assess hip ROM at a minimum 1-year follow-up in patients with either THA (larger diameter femoral heads) or hip resurfacing.²⁴ The authors noted that the arc of motion in the THA group ($\sim 20^\circ$, primarily in hip flexion and external rotation) was larger than the arc in the hip resurfacing group (flexion, 0-112.4; external rotation, 0-36.7). They postulated that this was due to the larger head-to-neck diameter ratio.

Hip ROM was examined in THA with 26- and 32-mm femoral heads to determine the effect of these heads on patients' ability to perform selected activities of daily living (eg, putting on and removing trousers and socks, cutting toenails).²⁵ Many patients in the 26-mm group adopted a compensatory position of lumbar flexion with hip flexion plus knee extension, whereas a majority of the patients in the 32-mm group used a more normal mode of hip flexion with knee flexion to perform these selected activities.

Although many studies of THA with larger femoral heads have demonstrated increased ROM, there is almost an equal number of studies showing otherwise. Le Duff and colleagues²⁶ reported no difference in hip ROM between hip resurfacing (large femoral heads) and THA, even after separating the cohort into 2 head-size groups (<40 mm, ≥ 40 mm). The authors concluded that, for most patients, prosthetic design is unlikely to be a factor limiting hip ROM after surgery provided that cup position is adequate.

In summary, biomechanical and clinical studies have shown that use of larger diameter femoral heads in THA increases hip

stability. The effect on hip ROM, however, is less clear. In THA, ROM increases with larger head diameters primarily because of increased stability and reduced impingement. Although this does not produce an obvious clinical advantage in many patients, it may normalize gait biomechanics and improve activities of daily living.

Wear

Femoral head size can affect polyethylene wear. Wear is a multifactorial phenomenon influenced by head size and many other implant factors (properties and composition of articulating parts; polyethylene quality and configuration) and patient factors (age, sex, activity level, weight).²⁷

The center of hip rotation affects wear through changes in joint reaction forces.²⁷ When the joint center is moved medially, inferiorly, and anteriorly, joint forces are minimized. This position increases the abductor lever arm and the moment-generating capacity of the abductors in turn decreasing the external moment that needs to be balanced by the muscle forces by bringing the hip center closer to the center of gravity. Consequently, when the joint center is moved superiorly, laterally, and posteriorly, as is the case with a dysplastic hip with cup placed in the false acetabulum, joint forces and moments are stronger. Therefore, more medial placement of the hip center affects wear beneficially,²⁷

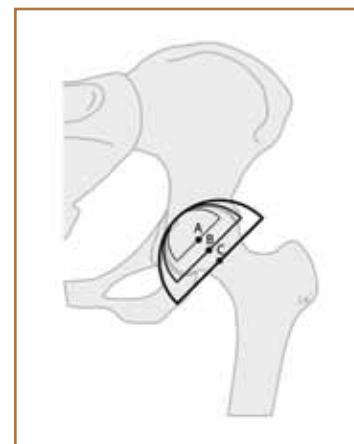

Figure 7. Larger acetabular component combined with larger femoral head lateralizes hip center. A, B, and C are the hip centers of sequentially larger heads paired with corresponding large cups.

by reducing joint reaction forces (Figures 6A, 6B). For larger femoral heads (>38 mm), there is often a head offset of about 3 mm as the cup design corresponds to a truncated hemisphere of 165°. This in effect lateralizes the hip center, increasing joint reaction forces and theoretically increasing wear (Figure 7).

Volumetric wear is a measure of the absolute amount of material removed from the bearing surface. The increased contact area and sliding distance of larger heads result in increased volumetric wear. This can be represented by the following simple cylindrical formula:

$$V = (\pi)R^2W$$

In the above V is the change in the volume of the polyethylene bearing (volumetric wear); R is the radius of the femoral head; and W is the measured linear wear. This formula demonstrates that for any given amount of linear wear, volumetric wear increases exponentially with increases in the radius of the bearing (head diameter). In a retrieval study, for each millimeter increase in head diameter, there was a volumetric-wear increase of 6.3 mm³ per year.²⁸

Clinical studies found rates of linear wear, osteolysis, and implant loosening of polyethylene against 32-mm femoral heads to be equivalent to or greater than those in heads with a smaller diameter.²⁸ Livermore and colleagues²⁹ reported higher volumetric wear rates for 32-mm femoral heads as well, in comparison with 28-mm heads. In another study, there was significantly (P<.001) more volumetric wear in THAs with 32-mm femoral heads (136 mm³/y) than in THAs with 28-mm heads (51 mm³/y).³⁰

The influence of head diameter on midterm (range, 2-12 years) cumulative revision rates was studied by Marston and colleagues³¹ in 1996 and by Kesteris and colleagues³² in 1998. They reported on outcomes of 413 and 1660 THAs (all conventional polyethylene), respectively, and found survival unaffected by head size. However, after follow-up of the 1660-patient of the Kesteris cohort by Tarasevicius 10 years later at 21 years after surgery, it was found that the 32-mm cohort had a higher risk for revision.

For larger femoral heads with either cross-linked or vitamin E-impregnated polyethylene, long-term wear rates and revision risks are yet unknown.

Biomechanical studies have found that conventional polyethylene and cross-linked polyethylene have different wear behavior. Hip simulator studies have shown extremely low wear rates for cross-linked polyethylene, independent of femoral head size (22-32 mm), and for head sizes up to 46 mm. Oral and colleagues³³ had similar wear rates for femoral head sizes of 22 to 46 mm. In addition, Bragdon and colleagues³⁴ reported cross-linked polyethylene third-body wear in a hip simulator, also independent of femoral head size.

Robinson and colleagues³⁵ reported on linear and volumetric wear rates of cross-linked polyethylene in 102 hips at 5- to 8-year follow-up. They used the method of Lachiewicz and colleagues³⁶ to compare large femoral heads (36-40 mm) with standard-size femoral heads (26, 28, 32 mm). Although there were no cases of pelvic or femoral osteolysis, and no association of head size with linear wear, there was more volu-

metric wear with the larger diameter heads. Lachiewicz and colleagues³⁶ cautioned against using larger femoral heads in young active patients at low risk for instability, as the longer term sequelae of increased volumetric wear are unknown.

Although the wear characteristics of improved polyethylenes have reduced the volume of wear particles to an almost undetectable level, larger diameter heads still cause more wear than smaller diameter heads and it is unclear if this amount of wear will translate into osteolysis and premature implant failure.

In conclusion, the biomechanical and clinical data support the finding of increased stability and increased ROM with use of larger diameter femoral heads—advantages that come at the cost of increased bearing surface wear, which may affect implant longevity. More clinical studies are needed to understand the clinical long-term effects of larger heads used with various bearing surfaces. Until these studies are completed, surgeons should use large femoral heads cautiously in young or active (high-demand) patients and in patients at low risk for instability. Large femoral heads provide an increased margin of error for stability in terms of component placement during surgery, but this advantage can be negated if the acetabular component is malpositioned.³⁵

Dr. Rathi is Clinical Fellow in Adult Reconstruction, University of California Davis Medical Center, Sacramento. Mr. Pereira is Assistant Professor, Department of Orthopedic Surgery, and Consultant, Adult Reconstructive Services, University of California Davis Medical Center, Sacramento. Dr. Giordani is Associate Professor, Department of Orthopaedic Surgery, Director, Adult Reconstruction Fellowship, and Chief, Adult Reconstructive Services, University of California Davis Medical Center, Sacramento. Dr. Di Cesare is Director, Total Joint Arthroplasty Service, New York Hospital, Queens.

Address correspondence to: Pranav Rathi, MBBS, MS, University of California Davis Medical Center, 4860 Y St, Suite 3800, Sacramento, CA 95817 (tel, 916-596-8225; fax, 916-734-7904; e-mail, pranavprathi@yahoo.com).

Am J Orthop. 2013;42(8):E53-E59. Copyright Frontline Medical Communications Inc. 2013. All rights reserved.

References

- Sariali E, Leonard P, Mamoudy P. Dislocation after total hip arthroplasty using Hueter anterior approach. *J Arthroplasty.* 2008;23(2):266-272.
- Alberston GM, High WA, Morrey BF. Dislocation after revision total hip arthroplasty: an analysis of risk factors and treatment options. *J Bone Joint Surg Am.* 2002;84(10):1788-1792.
- Bozic KJ, Kurtz SM, Lau E, Ong K, Vail TP, Berry DJ. The epidemiology of revision total hip arthroplasty in the United States. *J Bone Joint Surg Am.* 2009;91(1):128-133.
- Sanchez-Sotelo J, Haidukewych GJ, Boberg CJ. Hospital cost of dislocation after primary total hip arthroplasty. *J Bone Joint Surg Am.* 2006;88(2):290-294.
- Sariali E, Lazennec JY, Khiami F, Catonné Y. Mathematical evaluation of jumping distance in total hip arthroplasty: influence of abduction angle, femoral head offset, and head diameter. *Acta Orthop.* 2009;80(3):277-282.
- Bunn A, Colwell CW Jr, D'Lima DD. Bony impingement limits design-related increases in hip range of motion. *Clin Orthop.* 2012;470(2):418-427.
- Byström S, Espehuag B, Furnes O, Havelin LI; Norwegian Arthroplasty Register. Femoral head size is a risk factor for total hip luxation: a study of 42,987 primary hip arthroplasties from the Norwegian Arthroplasty Register. *Acta Orthop Scand.* 2003;74(5):514-524.
- Berry DJ, von Knoch M, Schleck CD, Harmsen WS. Effect of femoral head diameter and operative approach on risk of dislocation after primary total hip arthroplasty. *J Bone Joint Surg Am.* 2005;87(11):2456-2463.
- Jameson SS, Lees D, James P, et al. Lower rates of dislocation with

- increased femoral head size after primary total hip replacement: a five-year analysis of NHS patients in England. *J Bone Joint Surg Br*. 2011;93(7):876-880.
10. Lombardi AV Jr, Skeels MD, Berend KR, Adams JB, Franchi OJ. Do large heads enhance stability and restore native anatomy in primary total hip arthroplasty? *Clin Orthop*. 2011;469(6):1547-1553.
 11. dela Rosa MA, Silva M, Heisel C, Reich M, Schmalzried TP. Range of motion after total hip resurfacing. *Orthopedics*. 2007;30(5):352-357.
 12. MacWilliam CH, Yood MU, Verner JJ, McCarthy BD, Ward RE. Patient-related risk factors that predict poor outcome after total hip replacement. *Health Serv Res*. 1996;36(5):623-638.
 13. Röder C, Staub LP, Eggli S, Dietrich D, Busato A, Müller U. Influence of preoperative functional status on outcome after total hip arthroplasty. *J Bone Joint Surg Am*. 2007;89(1):11-17.
 14. D'Lima DD, Urquhart AG, Buehler KO, Walker RH, Colwell CW Jr. The effect of the orientation of the acetabular and femoral components on the range of motion of the hip at different head-neck ratios. *J Bone Joint Surg Am*. 2000;82(3):315-321.
 15. Bartz RL, Nobel PC, Kadakia NR, Tullos HS. The effect of femoral component head size on posterior dislocation of the artificial hip joint. *J Bone Joint Surg Am*. 2000;82(9):1300-1307.
 16. Ganz R, Parvizi J, Beck M, Leunig M, Nötzli H, Siebenrock KA. Femoroacetabular impingement: a cause for osteoarthritis of the hip. *Clin Orthop*. 2003;417:112-120.
 17. Krushell RJ, Burke DW, Harris WH. Range of motion in contemporary total hip arthroplasty. The impact of modular head-neck components. *J Arthroplasty*. 1991;6(2):97-101.
 18. Usrey MM, Noble PC, Rudner LJ, et al. Does neck/liner impingement increase wear of ultrahigh-molecular-weight polyethylene liners? *J Arthroplasty*. 2006;21(6 suppl 2):65-71.
 19. Urquhart AG, D'Lima DD, Venn-Watson E, Colwell CW Jr, Walker RH. Polyethylene wear after total hip arthroplasty: the effect of a modular femoral head with an extended flange-reinforced neck. *J Bone Joint Surg Am*. 1998;80(11):1641-1647.
 20. Barrack RL. Dislocation after total hip arthroplasty: implant design and orientation. *J Am Acad Orthop Surg*. 2003;11(2):89-99.
 21. Kummer FJ, Shah S, Iyer S, DiCesare PE. The effect of acetabular cup orientations on limiting hip rotation. *J Arthroplasty*. 1999;14(4):509-513.
 22. Crowninshield RD, Maloney WJ, Wentz DH, Humphrey SM, Blanchard CR. Biomechanics of large femoral heads: what they do and don't do. *Clin Orthop*. 2004;429:102-107.
 23. Mont MA, Seyler TM, Ragland PS, Starr R, Erhart J, Bhav A. Gait analysis of patients with resurfacing hip arthroplasty compared with hip osteoarthritis and standard total hip arthroplasty. *J Arthroplasty*. 2007;22(1):100-108.
 24. Lavigne M, Ganapathi M, Mottard S, Girard J, Vendittoli PA. Range of motion of large head total hip arthroplasty is greater than 28 mm total hip arthroplasty or hip resurfacing. *Clin Biomech (Bristol, Avon)*. 2011;26(3):267-273.
 25. Matsushita I, Morita Y, Ito Y, Gejo R, Kimura T. Activities of daily living after total hip arthroplasty. Is a 32-mm femoral head superior to a 26-mm head for improving daily activities? *Int Orthop*. 2011;35(1):25-29.
 26. Le Duff MJ, Wisk LE, Amstutz HC. Range of motion after stemmed total hip arthroplasty and hip resurfacing—a clinical study. *Bull NYU Hosp Jt Dis*. 2009;67(2):177-181.
 27. Sakalkale DP, Sharkey PF, Eng K, Hozack WJ, Rothman RH. Effect of femoral component offset on polyethylene wear in total hip arthroplasty. *Clin Orthop*. 2001;388:125-134.
 28. Schmalzried TP, Callaghan JJ. Wear in total hip and knee replacements. *J Bone Joint Surg Am*. 1999;81(1):115-136.
 29. Livermore J, Ilstrup D, Morrey B. Effect of femoral head size on wear of the polyethylene acetabular component. *J Bone Joint Surg Am*. 1990;72(4):518-528.
 30. Tarasevicius S, Robertsson O, Kesteris U, Kalesinskas RJ, Wingstrand H. Effect of femoral head size on polyethylene wear and synovitis after total hip arthroplasty: a sonographic and radiographic study of 39 patients. *Acta Orthop*. 2008;79(4):489-493.
 31. Marston RA, Cobb AG, Bentley G. Stanmore compared with Charnley total hip replacement. A prospective study of 413 arthroplasties. *J Bone Joint Surg Br*. 1996;78(2):178-184.
 32. Kesteris U, Robertsson O, Wingstrand H, Onnerfält R. Cumulative revision rate with the Scan Hip Classic I total hip prosthesis. 1,660 cases followed for 2-12 years. *Acta Orthop Scand*. 1998;69(2):133-137.
 33. Oral E, Christensen SD, Malhi AS, Wannomae KK, Muratoglu OK. Wear resistance and mechanical properties of highly cross-linked, ultrahigh-molecular weight polyethylene doped with vitamin E. *J Arthroplasty*. 2006;21(4):580-591.
 34. Bragdon CR, Kwon YM, Geller JA, et al. Minimum 6-year followup of highly cross-linked polyethylene in THA. *Clin Orthop*. 2007;465:122-127.
 35. Robinson RP, Simonian PT, Gradisar IM, Ching RP. Joint motion and surface contact area related to component position in total hip arthroplasty. *J Bone Joint Surg Br*. 1997;79(1):140-146.
 36. Lachiewicz PF, Heckman DS, Soileau ES, Mangla J, Martell JM. Femoral head size and wear of highly cross-linked polyethylene at 5 to 8 years. *Clin Orthop*. 2009;467(12):3290-3296.